



IJIRCCCE

e-ISSN: 2320-9801 | p-ISSN: 2320-9798



INTERNATIONAL JOURNAL OF INNOVATIVE RESEARCH

IN COMPUTER & COMMUNICATION ENGINEERING

Volume 12, Issue 2, April 2024

ISSN INTERNATIONAL
STANDARD
SERIAL
NUMBER
INDIA

Impact Factor: 8.379

9940 572 462

6381 907 438

ijircce@gmail.com

www.ijircce.com

IOT Based Patient Health Monitoring

Surekha S¹, Ramana G K², Vignesh M³, Aiswarya S⁴, NishaAngeline M⁵

UG. Students, Department of ECE, Velalar College of Engineering and Technology, Erode, Tamil Nadu, India ^{1 2 3}

Assistant Professor, Department of ECE, Velalar College of Engineering and Technology, Erode, Tamil Nadu, India⁴

Professor, Department of ECE, Velalar College of Engineering and Technology, Erode, Tamil Nadu, India⁵

ABSTRACT: Healthcare is given the extreme importance now a- days. In this aspect, an IoT based health monitoring system is the best solution. Internet of Things (IoT) is the new revolution of internet which is the growing research area especially in the health care. With the increase in use of wearable sensors and the smart phones, these remote health care monitoring has evolved in such a pace. IoT monitoring of health helps to get a proper diagnosis of the state of health, even if the doctor is at far distance. In this paper, a portable physiological checking framework is displayed, which can constantly screen the patient's heartbeat, temperature and other basic parameters of the room. We proposed a nonstop checking and control instrument to screen the patient condition and store the patient information's in cloud utilizing Wi-Fi Module. A remote health monitoring system using IoT is proposed where the authorized personal can access these data stored using any IoT platform and based on these values received and can diagnoses from a distance.

KEYWORDS: Healthcare Monitoring, IOT Devices, Wearable Gadgets, Sensors, Data, Health Information

I. INTRODUCTION

The healthcare industry is changing rapidly, with the advent of new technologies and innovations being introduced. In the past decade, the industry has seen a rapid increase in the utilization of wearable gadgets for patients, to monitor their health and provide better care. The use of these gadgets has revolutionized the healthcare industry, enabling healthcare professionals provide better care. Wearable gadgets have the potential to revolutionize the healthcare industry by providing better care for patients and making healthcare more efficient. By providing real-time data, healthcare professionals can quickly identify medical problems and provide better treatment for patients. The use of wearable gadgets can also reduce the cost of healthcare, as it eliminates the need for frequent doctor visits. The use of these gadgets can also enable healthcare professionals to provide preventive care to patients, as they can detect health problems before they become serious. Remote Patient Monitoring arrangement empowers observation of patients outside of customary clinical settings (e.g. at home), which expands access to human services offices at bring down expenses. The objective of this project is the design a smart patient health tracking system that uses sensors to track patient health and uses internet to inform about their health. The objective of developing monitoring systems is to reduce health care costs by reducing physician office visits, hospitalizations, and diagnostic testing procedure.

II. RELATED WORK

IoT is fast becoming popular in the healthcare sector, amongst others, with the ability to cost-effectively and efficiently gather critical data for processing though establishing innovative cyber physical systems. In healthcare, this technology – together with machine learning and computational intelligence techniques – provides for medical service innovation and the introduction of paradigm shifting medical frameworks. In fact, there is growing research and development in this area towards harnessing the aforementioned technologies to collate and fuse data from different streams to provide remote diagnosis, patient supervision and assistive treatment etc. [2, 3]. There are some recent works in the areas of application related to the proposed system. An example of this is presented in [1], which proposes an advanced IoT based system that combines remote health monitoring, home automation and security. The system monitors the heart rate, blood pressure, respiration rate, body temperature, body movement. Similarly, IoT-based systems which utilize mobile and wearable technologies are proposed in [4] and [10] for collection and interoperation of data. The data are collected primarily through wearables, but could also include other sensor data, to provide healthcare practitioners with physiological and environmental information of the person - in their natural living environment. In fact, the system proposed in [10] is based on wireless sensor networks, and is specifically intended for supervision and monitoring of pregnant women. It functions primarily on wearables or wireless body sensor networks for relaying information to the medical staff. Most of the proposed and implemented systems are a bit costly compared to our social and economic

context. In some cases, a wearable device has been able to transmit location information alone. Whereas other systems used infrared signals or tracked the log of the doors of the house to provide location specifically. Use of sensors was finalized according to the requirements of the system.

III. PROPOSED ALGORITHM

The healthcare industry is at an exciting crossroads with the emergence of new technologies. Wearable gadgets for patients have become increasingly popular in recent years, offering an unprecedented level of convenience and accuracy in the delivery of healthcare services.

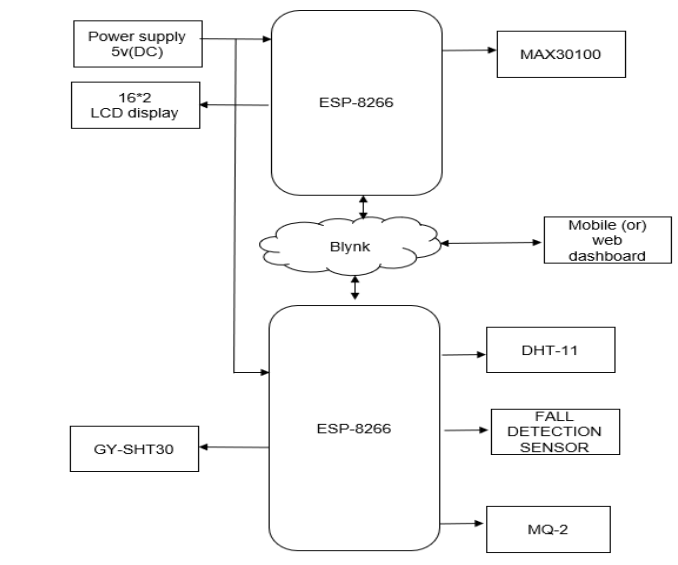

Fig 1 Block Diagram of the Proposed System

HEARTBEAT AND PULSE OXIMETER SENSOR

The MAX30100 is an integrated pulse oximetry and heart rate monitor sensor. Heartbeat sensor is utilized to gauge the computerized yield of a heart beat for every moment. It comprises of two LEDs discharges red light and other one radiates IR light where as to quantify the beat rate and IR light is required as the heart contract and afterward unwinds and the assurance of heartbeat rate by expanding or diminishing of oxygenated blood. SPO2 sensors are peripheral capillary oxygen saturation sensor which measures the level of oxygen saturation of the patient blood. This sensor has an infrared light source and photo detectors to transmit light



Fig 2 Heart Beat and Pulse Oximeter Sensor

TEMPERATURE SENSOR

GY-SHT30-D Digital Temperature and Humidity Sensor. GY-SHT30-D module for the digital measurement of temperature and relative humidity that equips the known sensor SHT30. It also offers new features, such as improved signal processing and two distinct user-selectable I2C address. Each SHT3x is individually calibrated and the calibration coefficients are programmed into an OTP memory on the chip. The compact size and low power consumption make SHT30 the ultimate choice for even the most demanding.



Fig3Temperature Sensor

DHT-11

The DHT11 is a commonly used Temperature and humidity sensor that comes with a dedicated NTC to measure temperature and an 8-bit microcontroller to output the values of temperature and humidity as serial data. It measures the surrounding temperature and humidity of the patient.

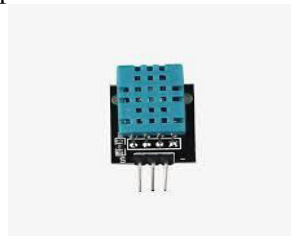

Fig4Temperature and Humidity Sensor

FALL DETECTION SENSOR

Fall alert devices contain a sensor called a triaxial accelerometer, which measures speed, distance, and direction. The accelerometer is programmed to look for the pattern of movement consistent in most falls: rapid downward acceleration followed by no movement.

CO SENSOR

The MQ2 gas sensor operates on 5 VDC and consumes approximately 800mW. It can detect PG, Smoke, Alcohol, Propane, Hydrogen, Methane and Carbon Monoxide concentrations ranging from 200 to 10000 ppm.



Fig5 CO Sensor

ESP-8266

Engineered for mobile devices, wearable electronics and IoT applications, ESP8266EX achieves low power consumption with a combination of several proprietary technologies. The power-saving architecture features three modes of operation: active mode, sleep mode and deep sleep mode. This allows battery-powered designs to run longer.

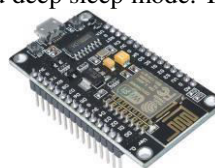

Fig6ESP-8266

BLYNK APP

Blynk responsible for all the communications between the smartphone and hard ware. You can use the Blynk Cloud or run your private Blynk server locally. It’s open-source, could easily handle thousands of devices.

VI. RESULTS AND DISCUSSIONS

This section explicates the experimental outcomes of the developed system which collects data from sensors.

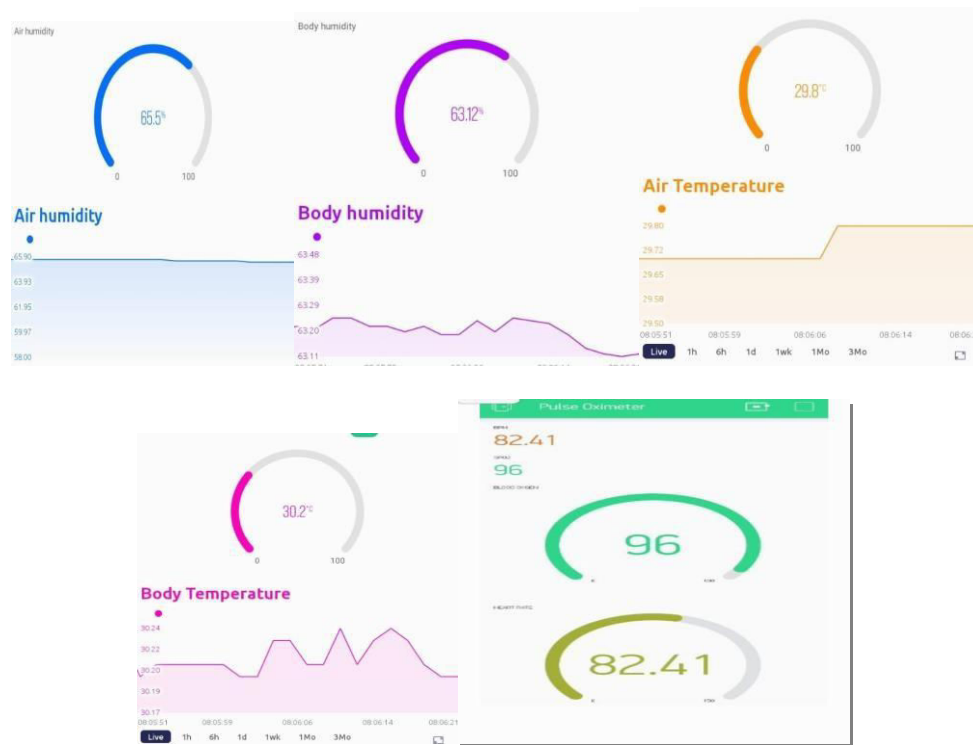

Fig7. Experimental test results for temperature, humidity, and fall detection measurements

The preliminary testing of both the wearable device and the room node –with the sub-nodes–was conducted using the microcontrollers’ serial monitors, to ensure correct retrieval of all sensor data in real-time. Thereafter, the incoming data fields on the Blynk platform were tested to ensure that the measured sensor data were correctly transmitted to cloud platform in real-time

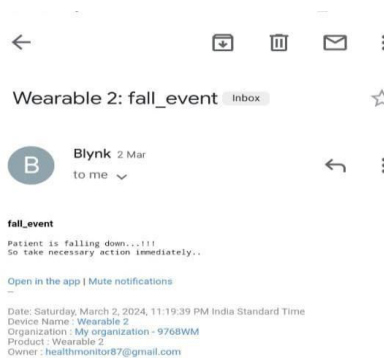

Fig 8 Experimental test results for system alert notifications sent via Email



V.CONCLUSION

This system introduces an IoT based health care monitoring system for patients. The proposed methodology work analyzes the variable health parameters values which are taken from sensors. Several precautions have been taken to ensure appropriate therapy, including regular monitoring of pulse rate, SpO2 level, and temperature. This system gives better and effective healthcare services to patients and the information is collected through internet and communication devices in turn connected to cloud services..By using this method where the doctor can check his patient anywhere, anytime. Emergency alert message will be to pre define demailid, if once the obtained current value is exceeded ordered the threshold value. This system is helpful for patients who need healthcare services at 24/7.

REFERENCES

1. J. Saha, A. K. Saha, A. Chatter, S. Agrawal, A. Saha, A. Kar, and H. N. Saha, "Advanced IOTBased combined remote health monitoring, home automation and alarm system," IEEE 8th annual computing and communication workshop and conference (CCWC), pp. 602 – 606, 2018.
2. P. Jangra, and M. Gupta, "A design of real time multilayered smart healthcare monitoring framework using IoT," IEEE International Conference on Intelligent and Advanced System(ICIAS), pp. 1 – 5, 2018.
3. A.He,J.Shen,Y.Wang,andL.Liu,"Researchonthefusionmodelreferencearchitectureofsensed information of human body for medical and healthcare IoT," IEEE 17th International Symposium on Distributed Computing and Applications for Business Engineering and Science (DCABES), pp. 162 – 164, 2018.
4. M. Haghi, S. Neubert, A. Geissler, H. Fleischer, N. Stoll, R. Stoll, and K. Thurow, "A Flexible and Pervasive IoT Based Healthcare Platform for Physiological and Environmental Parameters Monitoring," IEEE Internet of Things Journal, vol7, no. 6, 2020.
5. H.F. El-Sofany, and I.A. Taj-Eddin, "A Cloud based Model for Medical Diagnosis using Fuzzy Logic Concepts," IEEE International Conference on Innovative Trends in Computer Engineering (ITCE), pp. 162 – 167, 2019.
6. P.E. Idoga, M. Toycan, H. Nadiri, and E. Çelebi, "Factors affecting the successful adoption of e- health cloud based health system from healthcare consumers' perspective," IEEE Access, vol. 6, pp. 71216 – 71228, 2018.
7. K. Liu, Z. Chen, J. Wu, Y. Tan, L. Wang, Y. Yan, H. Zhang, and J. Long, "Big Medical Data Decision-Making Intelligent System Exploiting Fuzzy Inference Logic for Prostate Cancer in Developing Countries," IEEE Access, vol. 7, pp. 2348 – 2363, 2019.
8. D. Pal, S. Funilkul, N. Charoenkitkarn, and P. Kanthamanon, "Internet-of-things and smart homes for elderly healthcare: An end user perspective," IEEE Access, vol. 6, pp. 10483 – 10496, 2018.
9. V. Miori and D. Russo, "Improving life quality for the elderly through the Social Internet of Things (SIoT)," 2017 Global Internet of Things Summit (GIoTS), Geneva, 2017, pp. 1-6.
10. P. Pace, G. Aloï, G. Caliciuri, R. Gravina, C. Savaglio, G. Fortino, G. Ibáñez Sánchez, A. Fides- Valero, J. Bayo-Monton, M. Uberti, and M. Corona, "INTER-Health: An interoperable IoT solution for active and assisted living healthcare services," IEEE 5th World Forum on Internet of Things (WF-IoT), pp. 81 – 86, 2019.



INTERNATIONAL
STANDARD
SERIAL
NUMBER
INDIA



SJIF Scientific Journal Impact Factor



INTERNATIONAL JOURNAL OF INNOVATIVE RESEARCH

IN COMPUTER & COMMUNICATION ENGINEERING

 9940 572 462  6381 907 438  ijircce@gmail.com



www.ijircce.com

Scan to save the contact details